



---

# N2FB / N236FB / N366FB / N68FB / N810FB

## 3-Point Stationary Backstop System

---

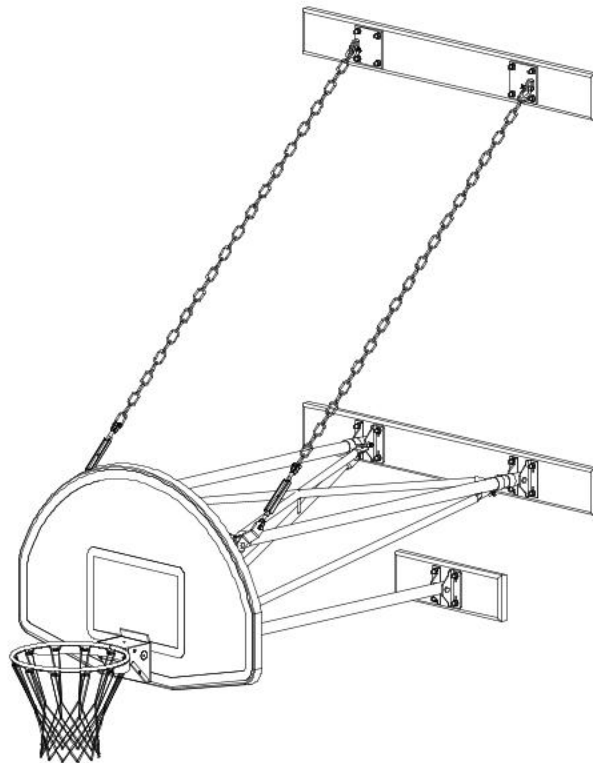

*jaypro sports*  
INNOVATION, PERFORMANCE AND COMMITMENT SINCE 1953

---

## Installation and Maintenance Manual

---

Call Jaypro Sports at 1-800-243-0533 during  
regular business hours for technical support.

[www.jaypro.com](http://www.jaypro.com)

## **IMPORTANT NOTES**

1. Only qualified and properly trained installers should attempt installation. Contact Jaypro to help locate a qualified installer if you cannot locate one.
2. Wall structure must be capable of supporting the entire load of the backstop and accessories, as well as the additional loading caused by an individual slam dunking and hanging on the rim. Jaypro Sports is not responsible for the wall structure or determining if the wall structure can support the backstop. Consult an Architect or Structural Engineer.
3. All wall anchors are supplied by others. Select the proper wall anchors for the given wall conditions. All wall anchors should be a minimum of 1/2" diameter. When possible, thru-bolting is preferred. If possible, thru-bolt at least two times per stringer, in addition to additional anchors. Consult an Architect or Structural Engineer when selecting wall anchors.
4. Acoustical block, or "sound block", is the worst possible masonry type for wall mounted backstops. The block facing is textured, and has vertical slots every few inches. Acoustical block must be filled solid at all attachment areas or failure is likely to occur.
5. Over the course of time, wall anchors and bolted connections may loosen as a result of building vibrations or vibrations caused during play. Periodic inspection and rework is strongly advised to tighten hardware and return the equipment to the original level of safety.
6. Follow all warning signs and labels on equipment.
7. Inspect all equipment before each use.
8. Should equipment become damaged, immediately stop using the system and tape off the area around the equipment. Do not continue using the equipment until a qualified service technician has inspected the equipment and certified the system is safe to resume use.
9. Use of the equipment other than intended, may be hazardous or cause damage to the equipment. Alterations or modifications of this equipment may be hazardous and result in injury. For repair or replacement, contact your dealer or Jaypro Sports.
10. Preventive maintenance should be performed annually to ensure years of safe, trouble-free use. This work must be completed by a qualified installer or technician. If one is not available to you, Jaypro's own field service team can be hired to do the work. Refer to the maintenance and inspection portion of this manual for further information.

### **\*\*\* IMPORTANT \*\*\***

Following all guidelines for installation is absolutely critical to ensure a successful and safe installation of wall mounted equipment. Be especially careful with regards to wall anchor selection and preparation. Follow all manufacturer's instructions for proper use of specific wall anchors. Jaypro does not supply wall anchors with wall mounted equipment, but they can be purchased directly from factory. Wall composition must be brick, concrete, or other form of solid or semi-solid masonry for the backstops to be supported securely. If wall composition is studded with either wood or steel, or there are obstructions or other such building features that make a standard installation inappropriate or impossible, do not attempt installation without first contacting Jaypro directly for a custom engineered solution. Jaypro will not assume liability for the installation of any wall mounted unit.

## PREPARATION

1. Begin by laying out all the parts. Identify everything listed on packing list and parts lists and make sure everything is accounted for. Contact Jaypro immediately if anything is missing. All hardware or component substitution must be reviewed and approved by Jaypro.
2. Familiarize yourself with the installation drawing packet supplied with the backstop. If you don't understand something on any of the drawings, now is the best time to contact Jaypro and get the answers to your questions.
3. Obtain correct anchors for the wall type present. Due to the fact that there are so many different types of wall construction, Jaypro does not supply wall anchors with the backstops. We do, however, stock the most common types and you can purchase the anchors directly from Jaypro. Refer to Appendix A for further information on wall anchors. **\*\*\*IMPORTANT\*\*\* It is the responsibility of the installer to supply the correct wall anchors. Jaypro will not be held liable should the wall anchors fail.**

## CHAIN SUPPORTS

1. The chain supports attach to the upper frame members. It is not allowed to attach the chain to the lower frame member. The location of the chain supports on the wall is dependent on the desired face of bank(FOB). **Please note, the chains supports must always be 45 degrees or greater.**
2. Verify the wall is of sufficient height to install the backstop. Verify there are no obstructions on or in the wall where the backstop is located. See table below for the required wall height.

	2' FOB (N2FB)	3'-6" FOB (N236FB)	6' FOB (N366FB)	8' FOB (N68FB)	10' FOB (N810FB)
REQUIRED WALL HEIGHT	11'-9"	15' - 5"	17' - 5"	19' - 5"	21' - 5"

Table 1: Required Wall Heights for Stationary Wall Mounted Units

3. If there is not sufficient height to install the chain supports, or it was determined that the upper wall structure is not structurally sound to hold the unit, the chains can also be installed to the ceiling structure above. If this approach is necessary, contact Jaypro Sports to design the attachments. Be ready to supply photos and dimensions of the ceiling structure.

## WALL MOUNT HORIZONTAL FRAME PIPES

1. Each wall mount kit is supplied with (3) three horizontal frame pipes that will need to be cut and drilled in the field. The length of the pipe is directly related to the face of bank (FOB) of the units (i.e. distance of the backboard off the wall).

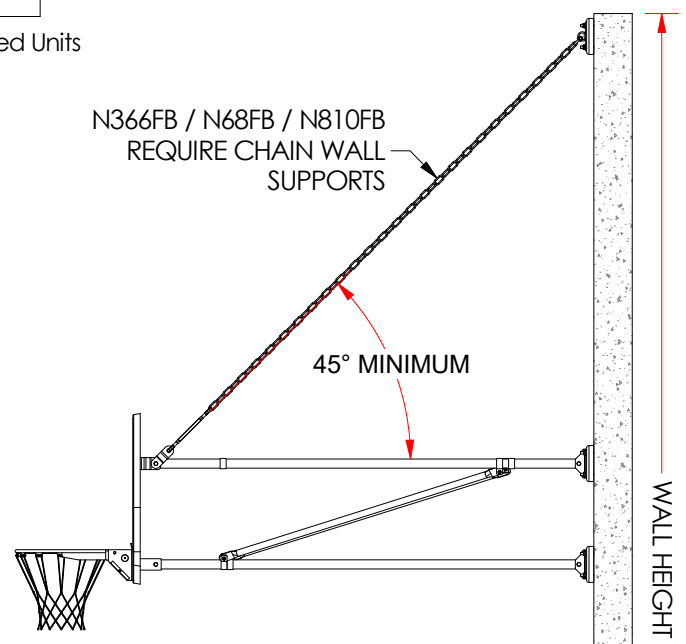
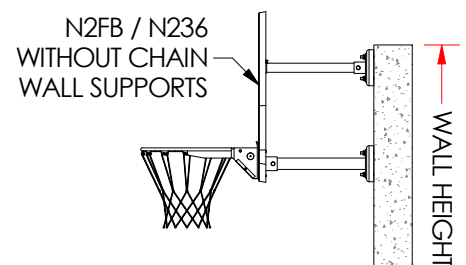



## DRILLING OF WOOD STRINGERS

1. Each wall mounted backstop is supplied with a wood stringer kit. Determine which kit was supplied with your backstop to determine the necessary installation requirements. Figure 1 illustrates the two stringer kits, WOOD-KT3 for N2FB and N236FB backstops and WOOD-KT4 for N366FB, N68FB, and N810FB backstops.

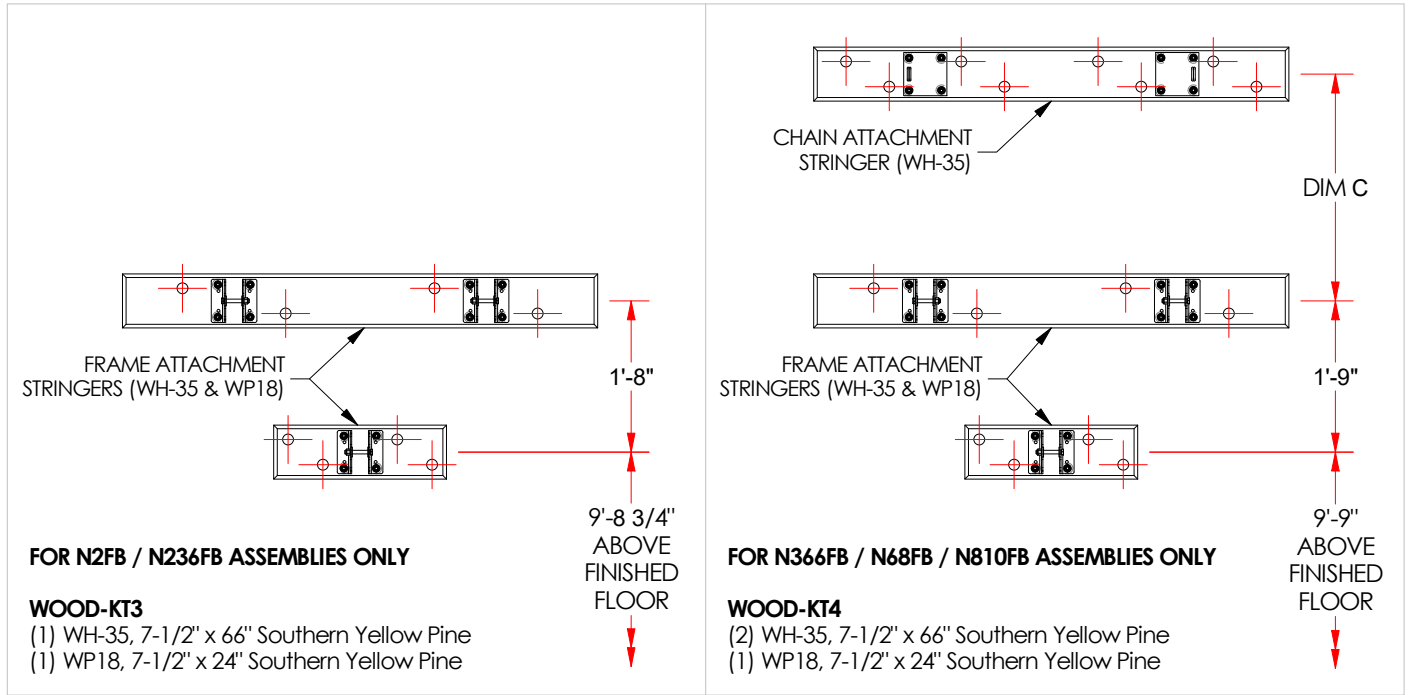

Figure 1: Wood Attachment Kits

- The wood stringers for attaching the backstop to the wall are predrilled for their specific brackets. Lay these out on a sawhorse or similar work area.
- It is best to use 1/2" anchors for the wall, therefore a 3/4" hole in the wood stringer is desirable to allow for leveling the stringer. Set up a drill with a 3/4" wood drill bit.
- When marking the stringer, mark and drill from the front of the stringer, the side facing away from the wall. This will be exposed as a finished product, so mark lightly. You need to drill from this side in order to prevent splintering when drilling. It is critical to ensure the holes are drilled as straight as possible, otherwise, it will become difficult to level the stringers during installation.
- Chain attachments (if equipped) are achieved using a 66" long stringer (WH-35). The chain attachments see the majority of the loading for wall mounted units. When anchoring the stringer to the wall, (8) eight anchors are required per stringer.
- The lower frame attachment is achieved using a 24" long stringer (WP18). The upper frame attachment is achieved using a 66" long stringer (WH-35). For either stringer, a minimum of (4) four anchors is required per stringer.
- Stagger the anchors from side to side to obtain optimal attachments and to protect against splitting the stringers. Exact anchor locations cannot be predetermined and is dependent on the wall structure. As a guideline, locate the holes approximately 2" inward from the closest side of the stringer. Use a repeated pattern throughout and locate the anchors close to the attachment fittings. Refer to Figure 1 as an example for anchor locations.



## LOCATING, DRILLING & SELECTING WALL ANCHORS

1. Now you are ready to transfer this layout to the wall for drilling. Determine the centerline of the unit from the drawings and architectural drawings. Determine the width of the frame from your installation drawings. The bottom frame attachment is indicated on your drawings, this will dictate the location of your bottom hole. Relate this point to your anchor pattern. Mark a centerline of the stringer starting at your bottom anchor location and extending to the top anchor location. Mark the actual hole locations to each side of the center as they are located on the stringer. Try to avoid mortar joints they often contain wire mesh. Continue marking the chain stringer anchor locations. These points may be shifted slightly to obtain desired anchor locations. **\*\*\*IMPORTANT\*\*\* For CMU walls, avoid attachment in the top 2 or 3 rows of the block wall. The top rows of a CMU wall typically are not strong enough and may not be capable of supporting the backstop.**

2. After marking all the anchor locations, double check before drilling. Make certain they are at the right height, width, and distance apart. If you are over a finished floor, make certain to protect the area prior to drilling. A box taped to the wall under each hole as you drill will catch a large portion of the dust. Drill all holes before attaching the stringers. Clean the area thoroughly before proceeding to prevent spreading masonry dust.

3. **\*\*\*IMPORTANT\*\*\* Determine the proper anchor for each location. All wall anchors are the responsibility of the installer. All wall anchors must be 1/2" hardware minimum.** A combination of different types of anchors may be necessary and is acceptable. If conditions allow, thru-bolting is the preferred method of attachment. If thru-bolting at all locations is not possible, at least two of the anchors should be thru-bolted for each stringer. Do not try to use an anchor that is not suited to the location. For instance, don't use an expansion anchor in a hollow wall application. Suitable toggle bolt anchors are available for hollow wall applications. If you carry a variety to allow for different applications, you will save yourself a huge amount of time and trouble, and do a better job at the same time. If you use a double expansion anchor, make sure you use a back-up washer between the wall and plank to prevent the anchor from pulling into the wood. Use a suitable washer at the face of the plank to cover the hole. Washers with 1-1/2" outside diameter work well. For additional information on selecting the proper wall anchors, refer to Appendix A, Anchor Management.

## CUT AND DRILL HORIZONTAL FRAME PIPES

1. The wall mount units are supplied as a "cut and drill" unit to allow maximum flexibility for the installer. Determine the desired face-of-bank (FOB) from the customer and reference the appropriate table (see sheets 8-12). Given the FOB, determine the frame pipe dimensions required.

2. When cutting the pipe, ensure the pipe is cut as straight as possible. Follow the dimensions given on the chart to locate the hole(s) needed for each pipe. Pay attention to the orientation of the holes to be drilled. The accuracy of the FOB is dependent on the accuracy of the cutting and drilling.

## 6" TO 2' FACE OF BANK (N2FB)

Follow the appropriate table for stringer locations. Cut and drill the frame pipes as directed.

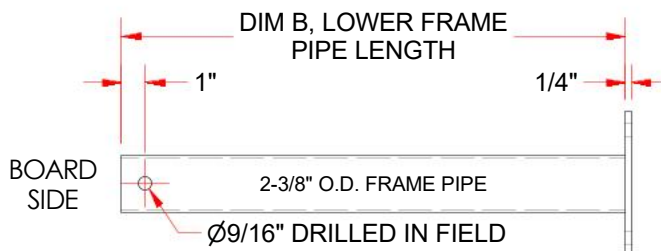
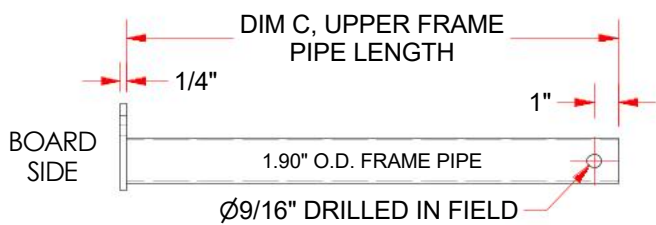
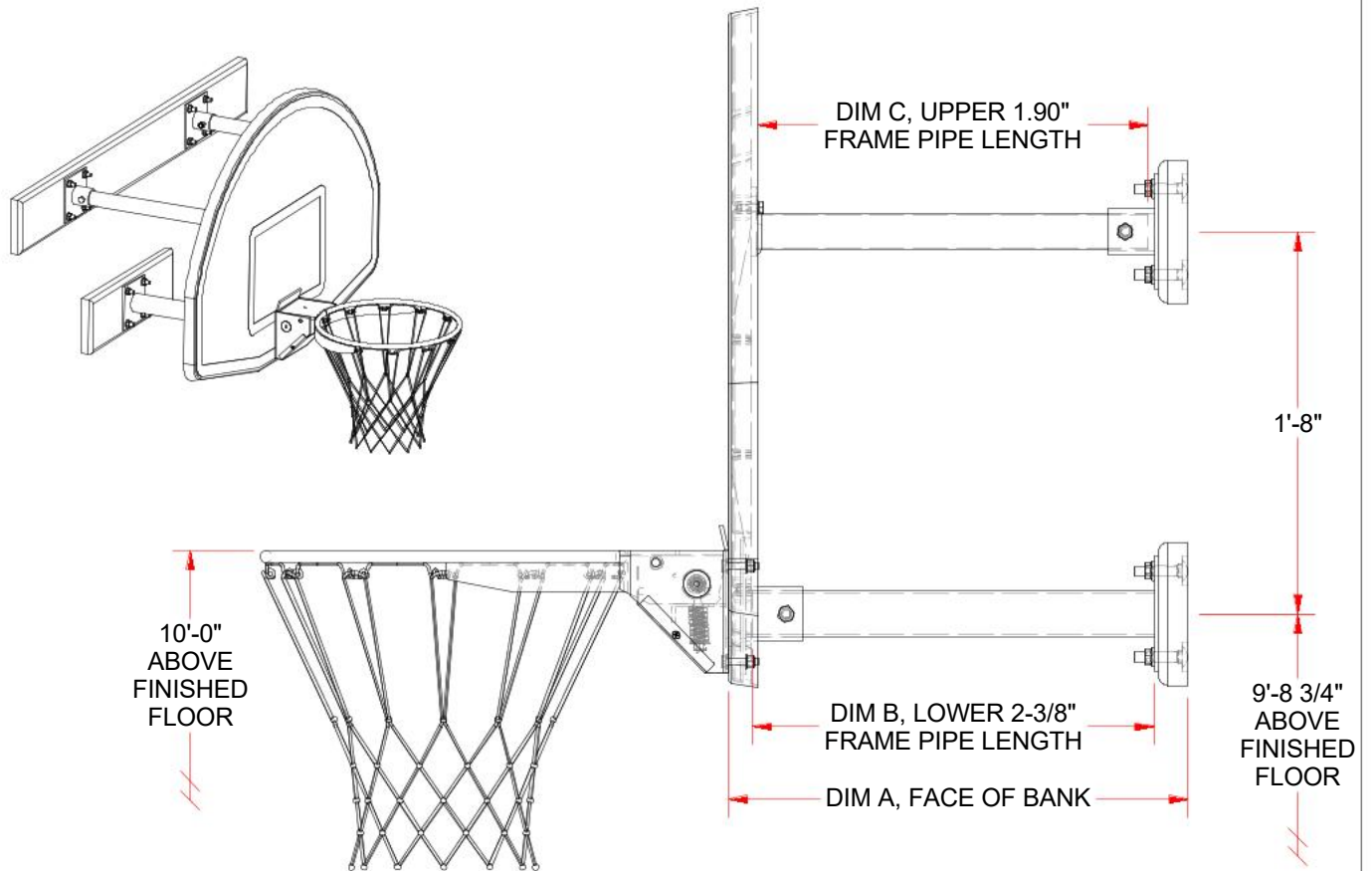

N2FB, DIRECT ATTACHED	DIM A, FACE OF BANK	DIM B (in)	DIM C (in)
	6"	2 1/4	2 1/4
	7"	3 1/4	3 1/4
	8"	4 1/4	4 1/4
	9"	5 1/4	5 1/4
	10"	6 1/4	6 1/4
	11"	7 1/4	7 1/4
	1'-0"	8 1/4	8 1/4
	1'-1"	9 1/4	9 1/4
	1'-2"	10 1/4	10 1/4
	1'-3"	11 1/4	11 1/4
	1'-4"	12 1/4	12 1/4
	1'-5"	13 1/4	13 1/4
	1'-6"	14 1/4	14 1/4
	1'-7"	15 1/4	15 1/4
	1'-8"	16 1/4	16 1/4
	1'-9"	17 1/4	17 1/4
	1'-10"	18 1/4	18 1/4
	1'-11"	19 1/4	19 1/4
	2'-0"	20 1/4	20 1/4

# Jaypro 3-Pt Stationary Wall Mount Backstop - Installation & Operating Manual

## 2' TO 3'-6" FACE OF BANK (N236FB)

Follow the appropriate table for stringer locations. Cut and drill the frame pipes as directed. Frame assembly also includes two diagonal braces that must be installed in the orientation shown below.

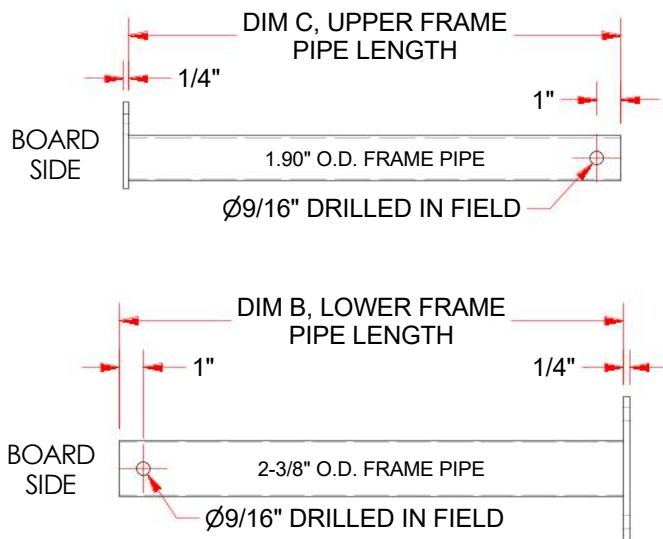
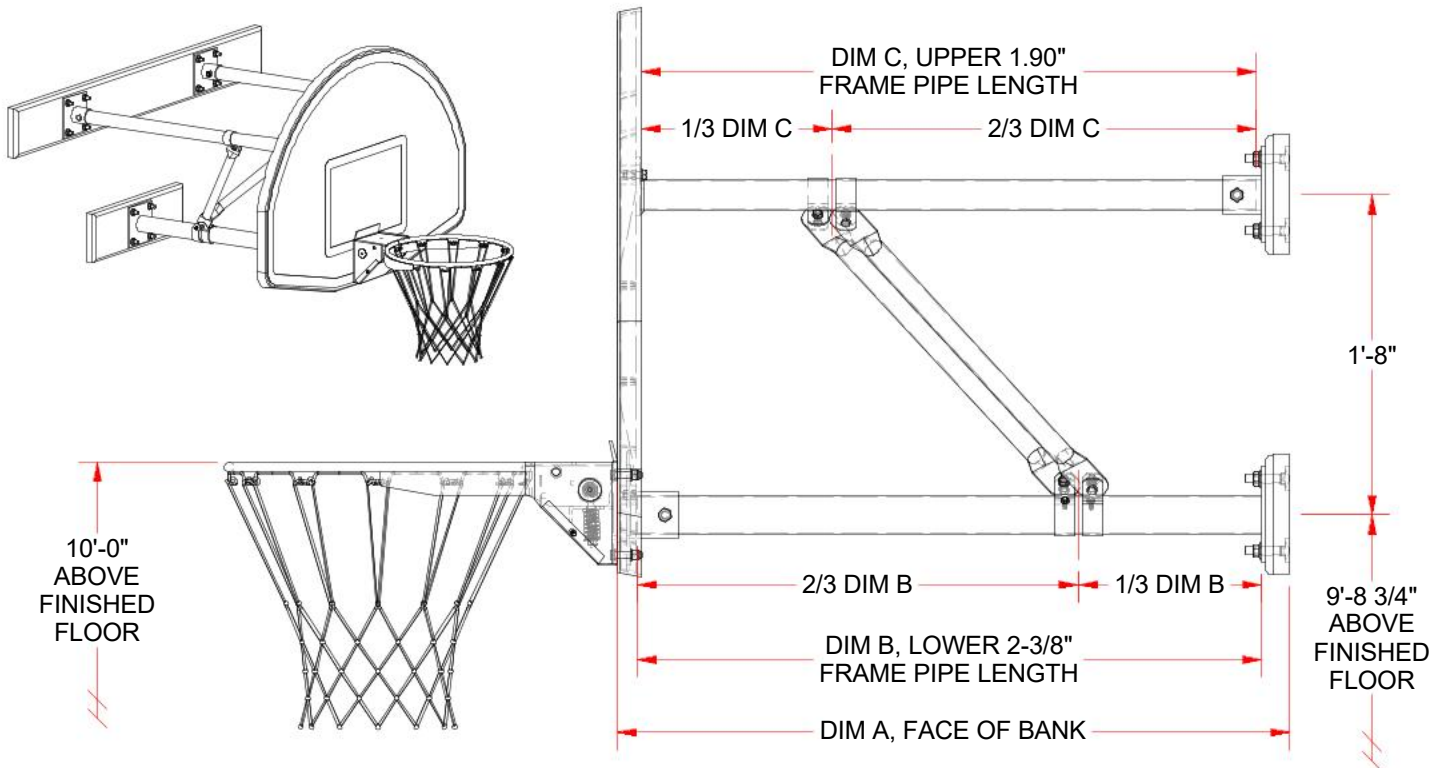

N236FB, DIRECT ATTACHED	DIM A FACE OF BANK	DIM B (in)	DIM C (in)
	2'-0"	20 1/4	20 1/4
	2'-1"	21 1/4	21 1/4
	2'-2"	22 1/4	22 1/4
	2'-3"	23 1/4	23 1/4
	2'-4"	24 1/4	24 1/4
	2'-5"	25 1/4	25 1/4
	2'-6"	26 1/4	26 1/4
	2'-7"	27 1/4	27 1/4
	2'-8"	28 1/4	28 1/4
	2'-9"	29 1/4	29 1/4
	2'-10"	30 1/4	30 1/4
	2'-11"	31 1/4	31 1/4
	3'-0"	32 1/4	32 1/4
	3'-1"	33 1/4	33 1/4
	3'-2"	34 1/4	34 1/4
	3'-3"	35 1/4	35 1/4
3'-4"	36 1/4	36 1/4	
3'-5"	37 1/4	37 1/4	
3'-6"	38 1/4	38 1/4	



## 3'-6" TO 6' FACE OF BANK (N366FB)

Follow the appropriate table for stringer locations. Cut and drill the frame pipes as directed. The N366FB includes two vertical diagonal braces and cross bracing on the top frame members that must be installed in the orientations shown below.

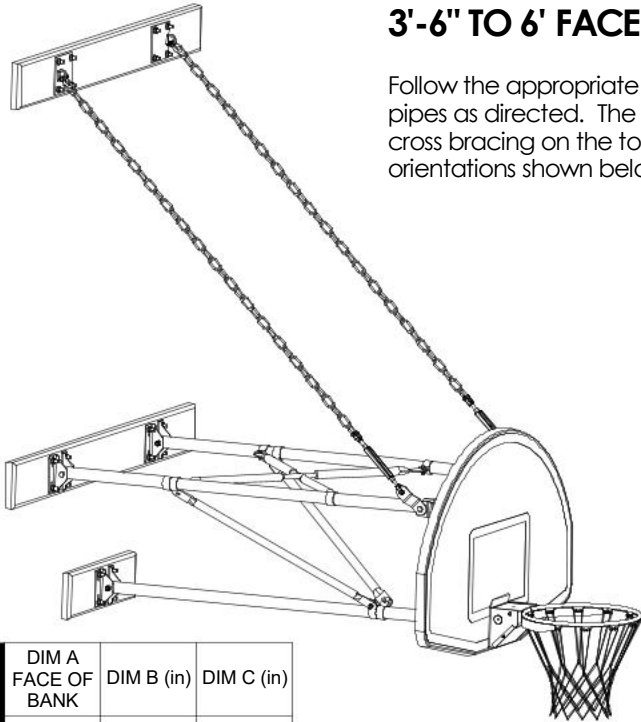

N366FB, DIRECT ATTACHED

DIM A FACE OF BANK	DIM B (in)	DIM C (in)
3'-6"	36 1/8	35
3'-7"	37 1/8	36
3'-8"	38 1/8	37
3'-9"	39 1/8	38
3'-10"	40 1/8	39
3'-11"	41 1/8	40
4'-0"	42 1/8	41
4'-1"	43 1/8	42
4'-2"	44 1/8	43
4'-3"	45 1/8	44
4'-4"	46 1/8	45
4'-5"	47 1/8	46
4'-6"	48 1/8	47
4'-7"	49 1/8	48
4'-8"	50 1/8	49
4'-9"	51 1/8	50
4'-10"	52 1/8	51
4'-11"	53 1/8	52
5'-0"	54 1/8	53
5'-1"	55 1/8	54
5'-2"	56 1/8	55
5'-3"	57 1/8	56
5'-4"	58 1/8	57
5'-5"	59 1/8	58
5'-6"	60 1/8	59
5'-7"	61 1/8	60
5'-8"	62 1/8	61
5'-9"	63 1/8	62
5'-10"	64 1/8	63
5'-11"	65 1/8	64
6'-0"	66 1/8	65

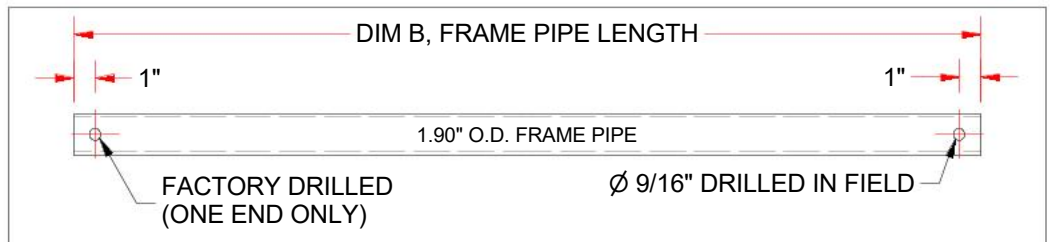
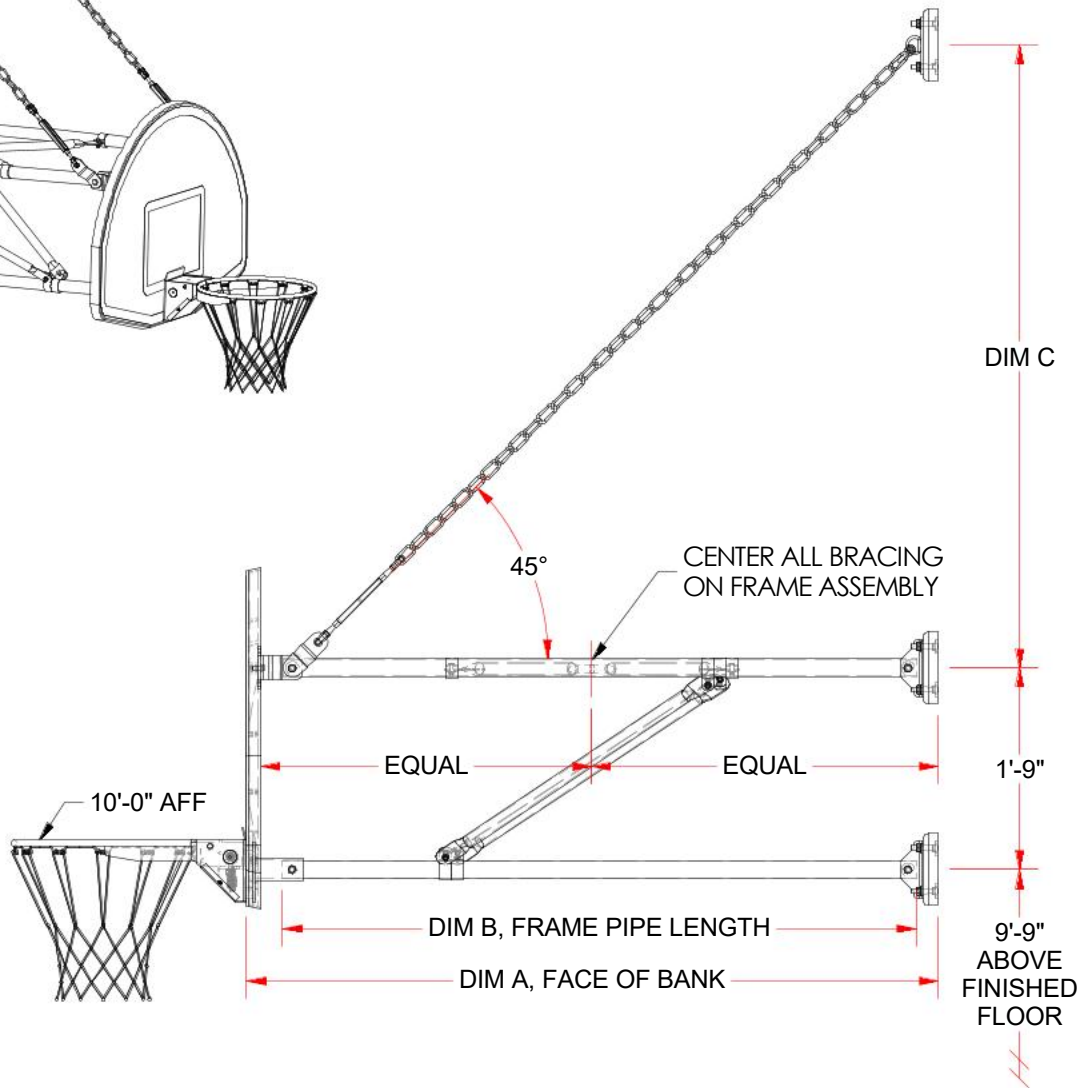





## 8' TO 10' FACE OF BANK (N810FB)

Follow the appropriate table for stringer locations. Cut and drill the frame pipes as directed. The N810FB includes six vertical braces and two sets of cross bracing on the top frame members that must be installed in the orientations shown below.

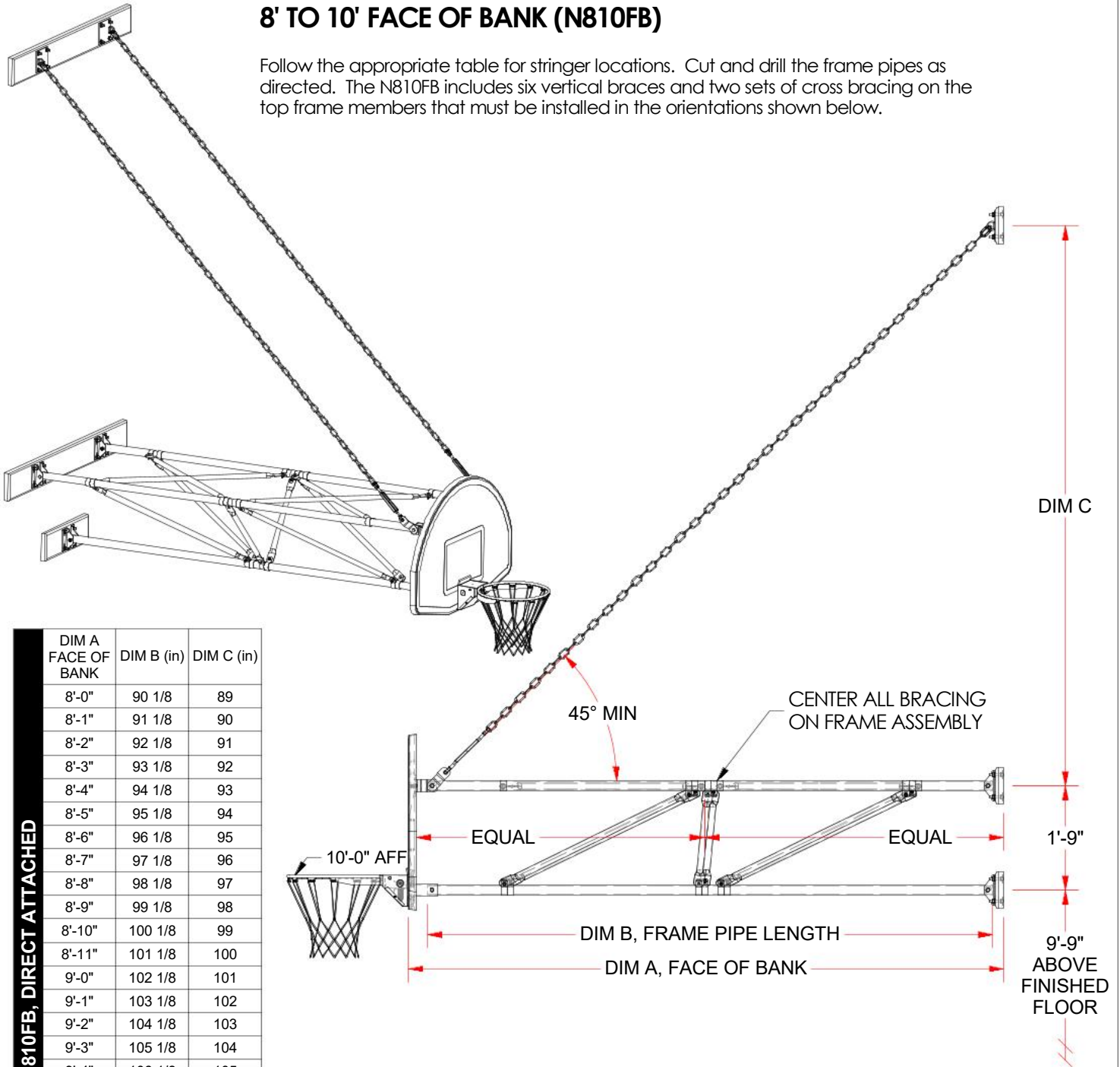

N810FB, DIRECT ATTACHED

DIM A FACE OF BANK	DIM B (in)	DIM C (in)
8'-0"	90 1/8	89
8'-1"	91 1/8	90
8'-2"	92 1/8	91
8'-3"	93 1/8	92
8'-4"	94 1/8	93
8'-5"	95 1/8	94
8'-6"	96 1/8	95
8'-7"	97 1/8	96
8'-8"	98 1/8	97
8'-9"	99 1/8	98
8'-10"	100 1/8	99
8'-11"	101 1/8	100
9'-0"	102 1/8	101
9'-1"	103 1/8	102
9'-2"	104 1/8	103
9'-3"	105 1/8	104
9'-4"	106 1/8	105
9'-5"	107 1/8	106
9'-6"	108 1/8	107
9'-7"	109 1/8	108
9'-8"	110 1/8	109
9'-9"	111 1/8	110
9'-10"	112 1/8	111
9'-11"	113 1/8	112
10'-0"	114 1/8	113

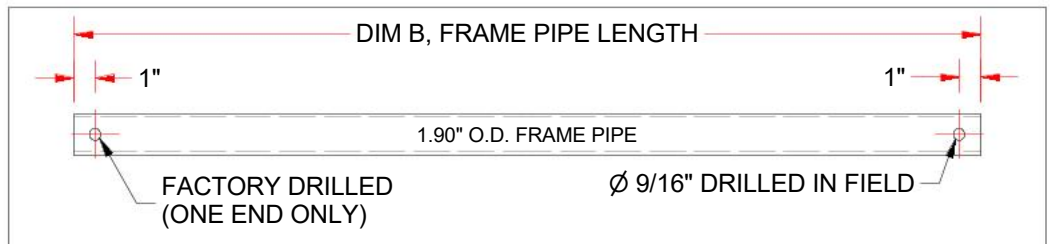



## ASSEMBLING THE UNIT

1. Prepare the wood stringers for installation by attaching all brackets with carriage bolts provided. Tighten these sufficiently to cause the bolt to compress into the stringer. Use a speed square to ensure the brackets are secured square.
2. Attach each stringer loosely, to allow for leveling. Level and tighten the stringers securely to the wall and cut off excess bolts protruding from the wall. Maintain center-to-center dimensions and height requirements as accurately as possible to make the rest of the installation as easy as possible.
3. If equipped, attach support chains to the stringers before attempting to assemble the frames, these are normally needed to support the frames after raising them. It is easier to have them in place before proceeding.
4. It may be easier to assemble each frame on the ground, including all x-bracing that is required. Ensure all BRC-190-A clamps are loosely slid onto the frame before attaching the horizontal frame pipes to the wall.
5. As shown in Figure 3, attach the top frame to the wood stringer and support the frame with the support chain and turnbuckle. Adjust the turnbuckles to level the frame structure and to evenly distribute the weight of the unit. Next, attach the lower frame to the wood stringer. Use a rated ratchet strap to hold the lower frame structure in the approximate location.
6. With all the frame structure installed, attach the backboard to the frame. **\*\*\*IMPORTANT\*\*\* Always secure the board to the frame supported by the chains FIRST. Never attach the board to the frame supported by the ratchet straps.** The ratchet straps should only see the weight of the frame itself. With the board secured to the frame at all four corners, adjust the turnbuckles as needed and remove the ratchet straps.
7. Cut off any excess chain.
8. Adjust and secure all frame bracing at this time.
9. Quite often, any wall anchors or bolted connections to wood stringers can become loose after the anchors see loading. This is caused by the additional compression of the wood. Once final assembly is complete, check all wall anchors and bolted connections for tightness.

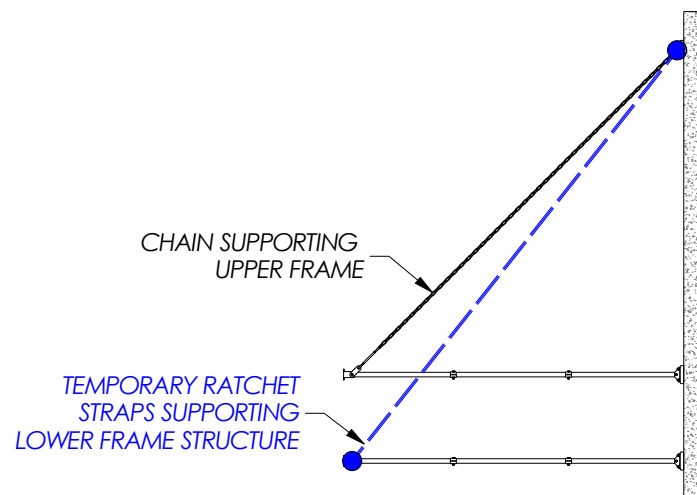
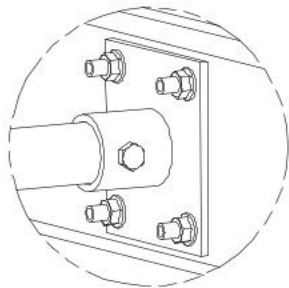
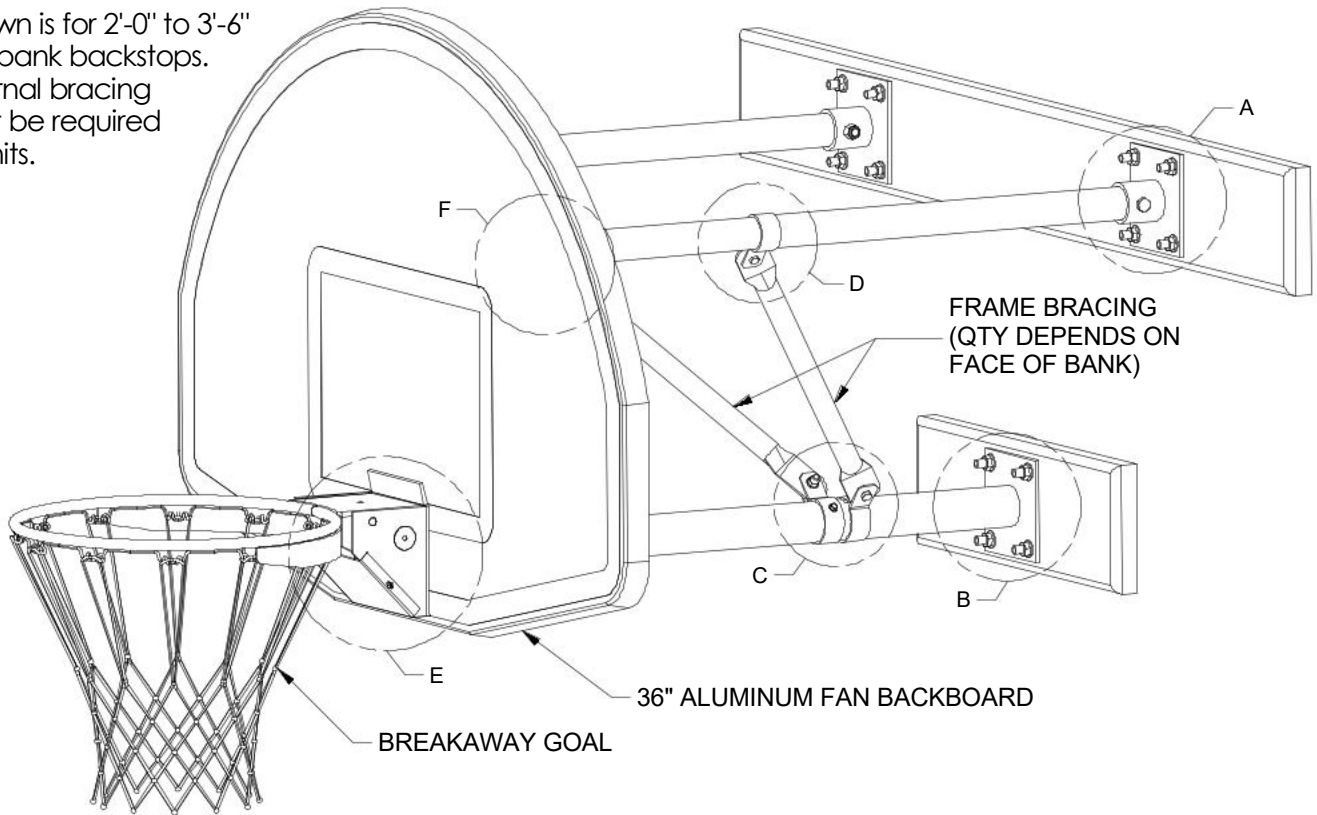

Figure 3: Supporting the Frame Assembly

## SYSTEM OVERVIEW - BACKSTOPS WITHOUT CHAIN SUPPORT

Unit shown is for 2'-0" to 3'-6" face of bank backstops. The internal bracing may not be required for all units.



DETAIL A

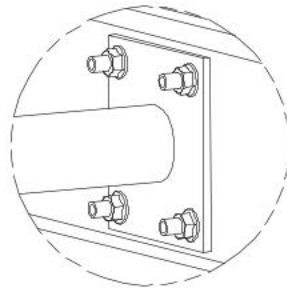

DETAIL B

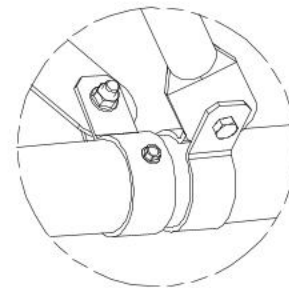

DETAIL C

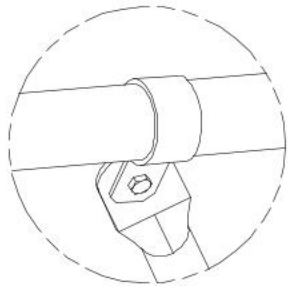

DETAIL D

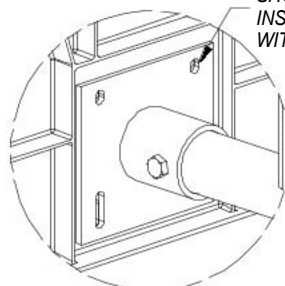

DETAIL E

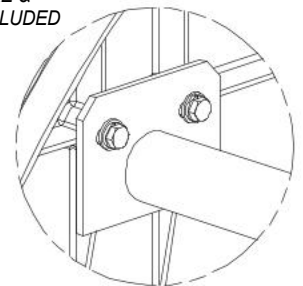

DETAIL F

GOAL HARDWARE NOT SHOWN (HARDWARE & INSTRUCTIONS INCLUDED WITH GOAL)



## N2FB / N236FB ASSEMBLY DETAILS

Refer to the proper table for the cut / drill requirements for the proper face of bank. For units requiring diagonal bracing, make sure to slide on the brace clamp to frame piping before installing. Bottom brace clamps must be secured with self tapping screw provided.

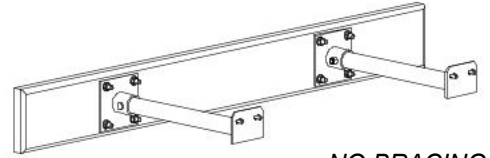

NO BRACING  
REQUIRED

### N2FB

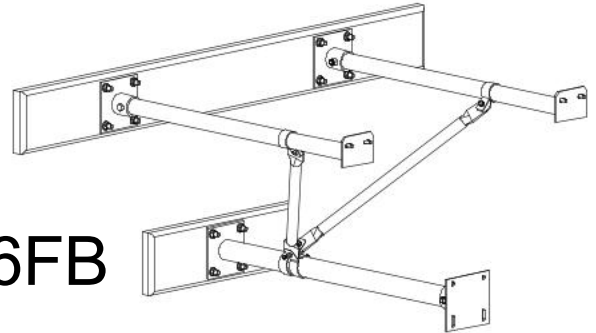
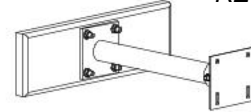

### N236FB

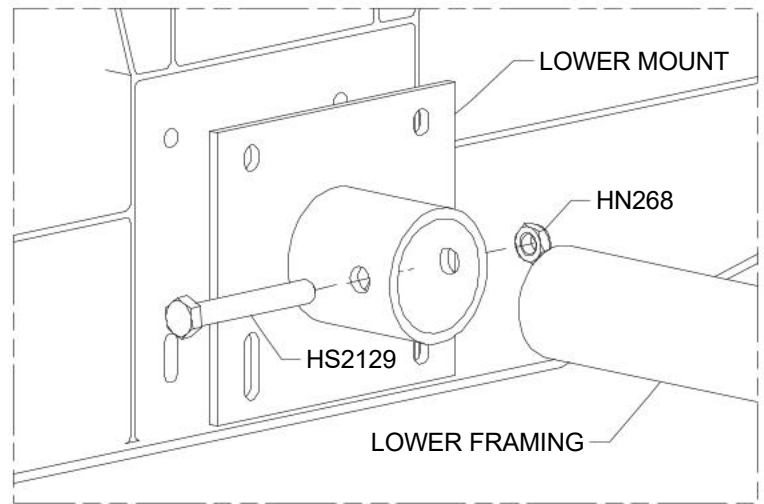
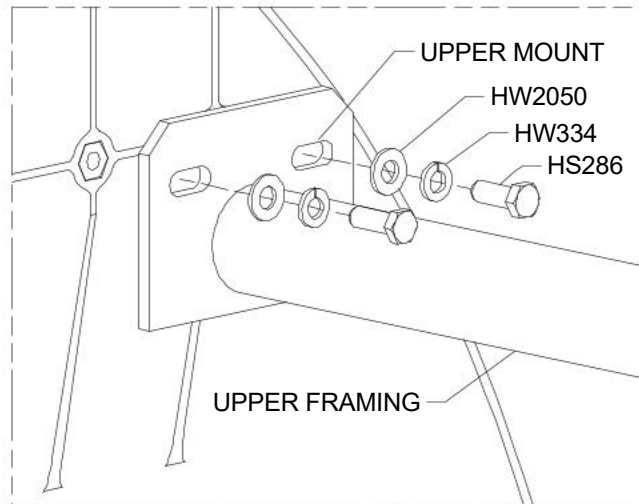
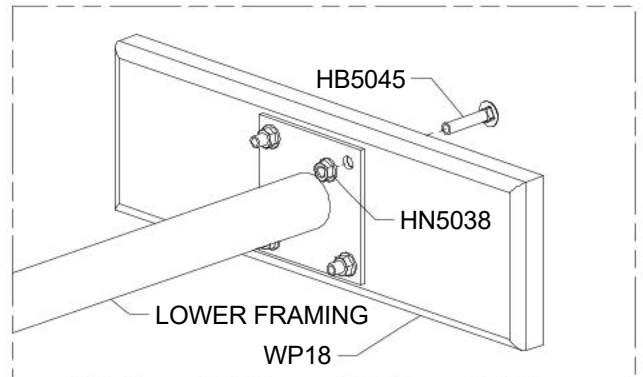
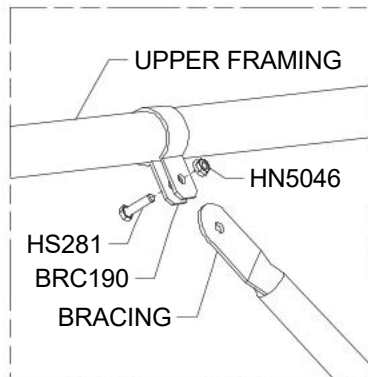
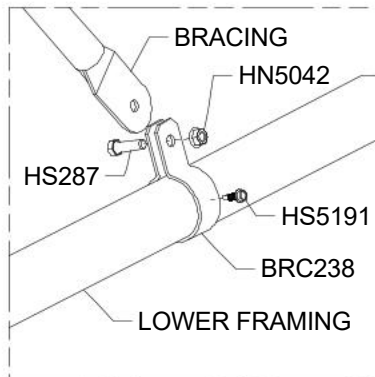
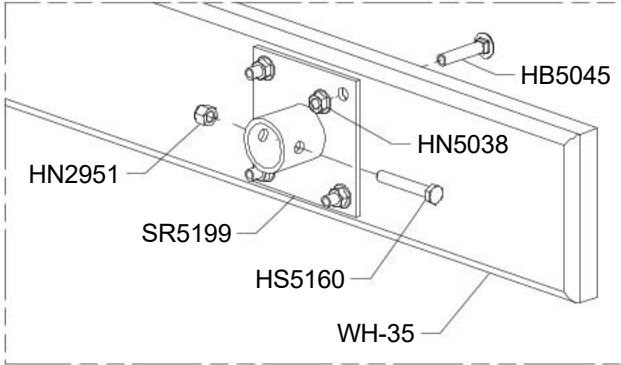

**N366FB / N68FB SYSTEM OVERVIEW**

Refer to the proper table for the cut / drill requirements for the proper face of bank. Make sure to slide on the brace clamp to frame piping before installing.

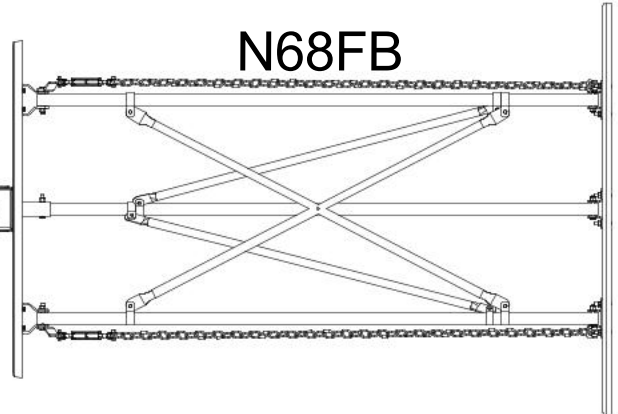
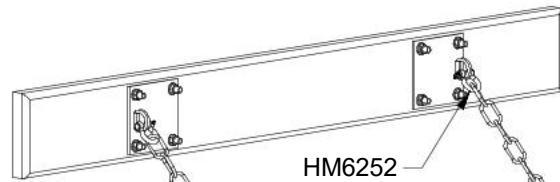

**N68FB**

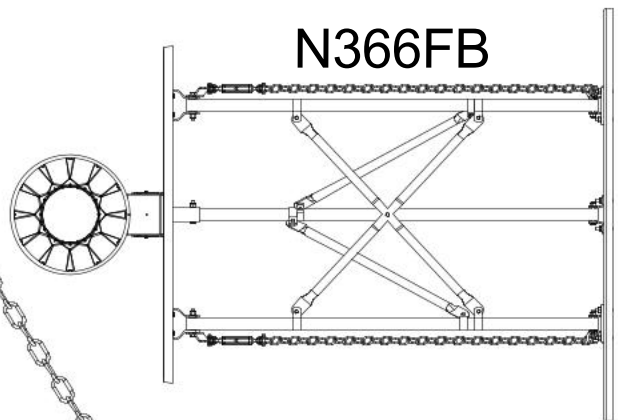

**N366FB**

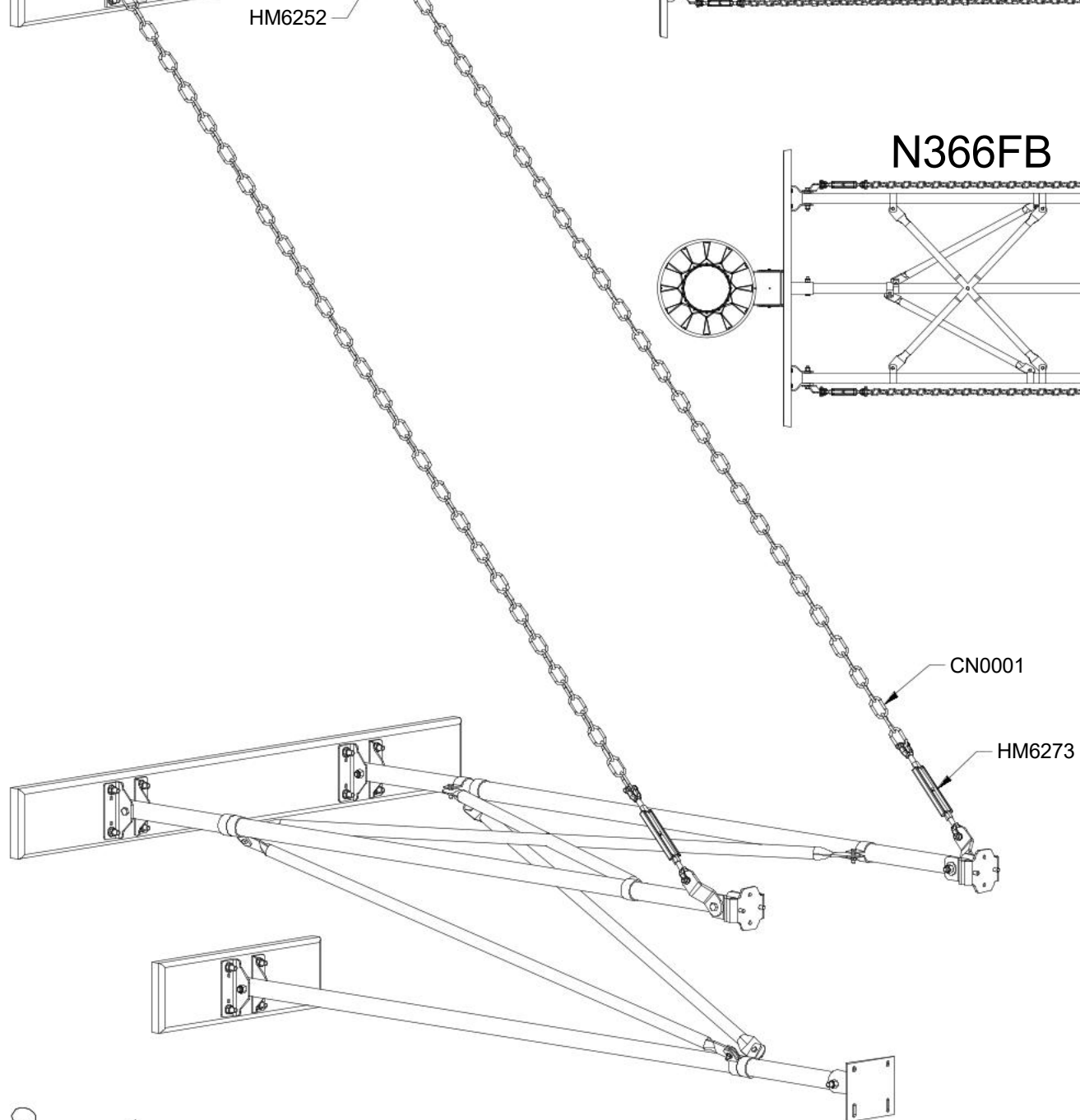

CN0001

HM6273

## **N810FB SYSTEM OVERVIEW**

Refer to the proper table for the cut / drill requirements for the proper face of bank. Make sure to slide on the brace clamp to frame piping before installing.

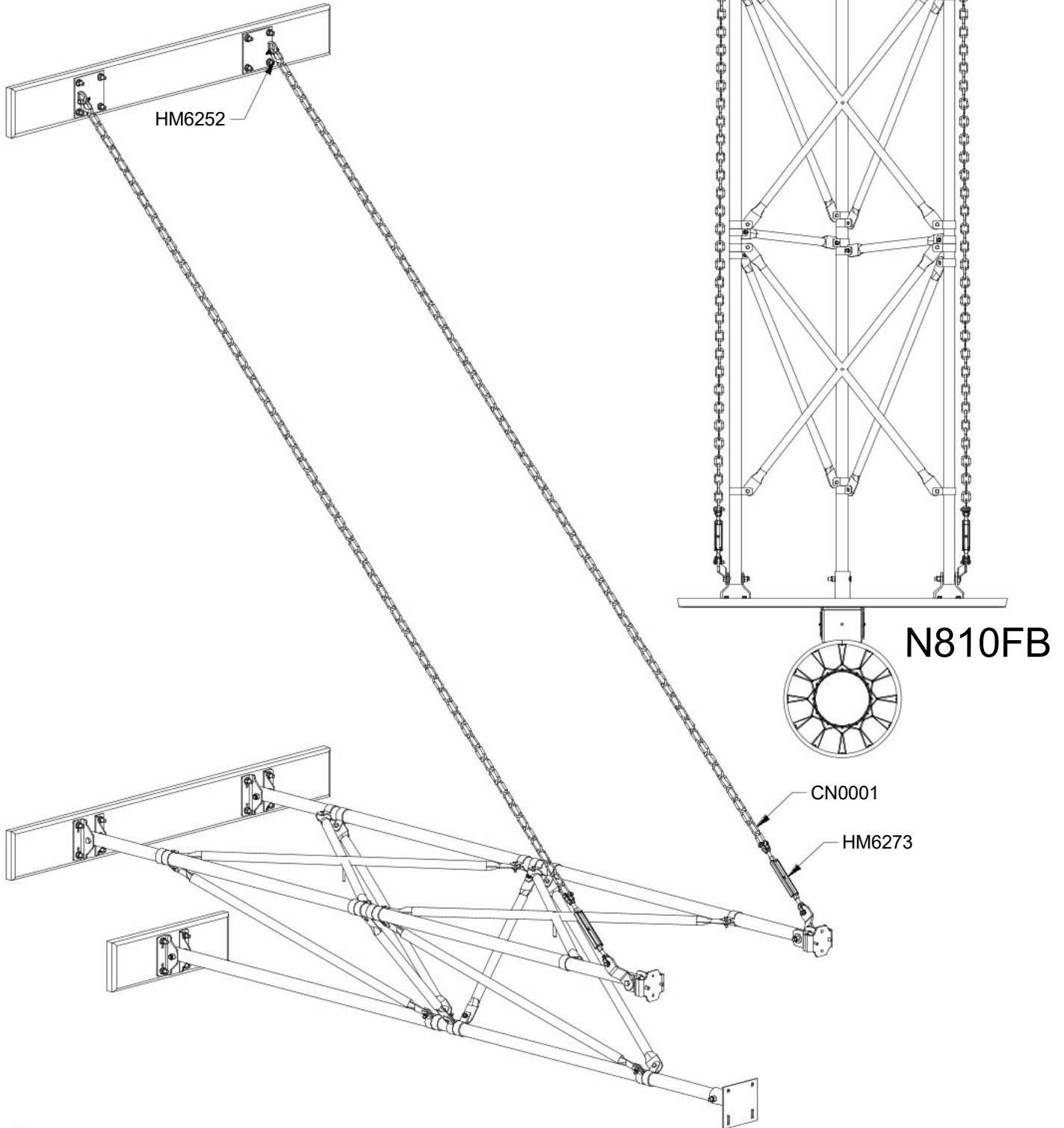

## SYSTEM OVERVIEW - BACKSTOPS WITH CHAIN SUPPORT

Unit shown is for 6'-0" to 8'-0" face of bank backstops. The support chains and internal bracing may vary slightly from other units.

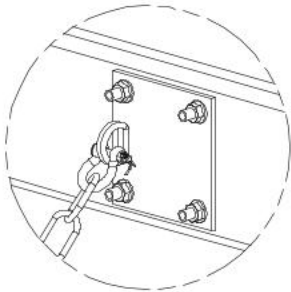

**DETAIL G**  
DPLATE-OS-A

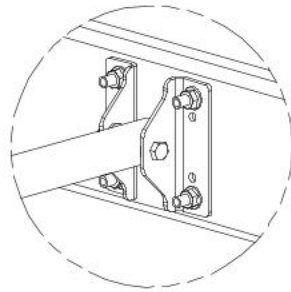

**DETAIL H**  
WMHB-166-A

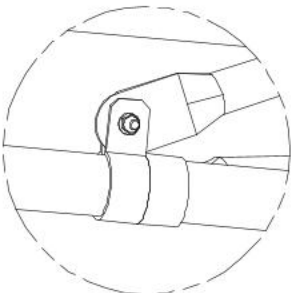

**DETAIL J**  
BRC-190-A

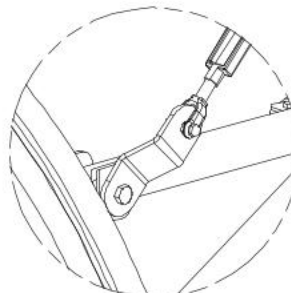

**DETAIL K**  
HPBH-P-A

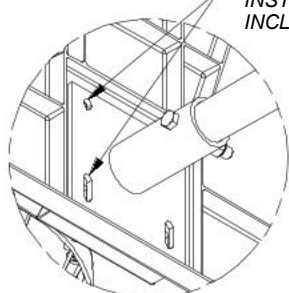

**DETAIL L**  
N366FB-A

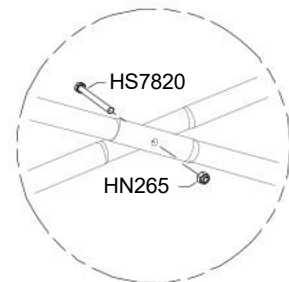

**DETAIL M**  
X-BRACING

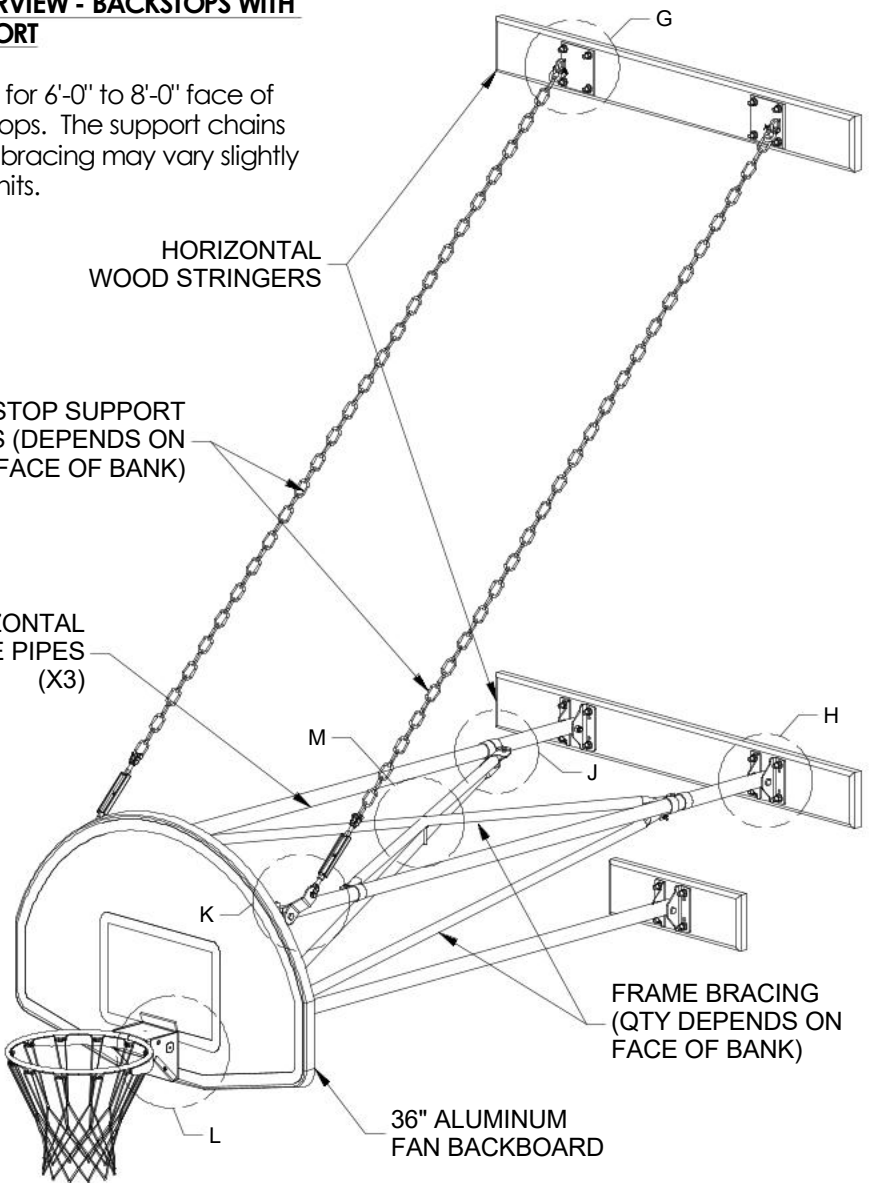

GOAL HARDWARE NOT SHOWN (HARDWARE & INSTRUCTIONS INCLUDED WITH GOAL)

## N366FB / N68FB / N810FB ASSEMBLY DETAILS

Refer to the proper table for the cut / drill requirements for the proper face of bank. Make sure to slide on the brace clamp to frame piping before installing.

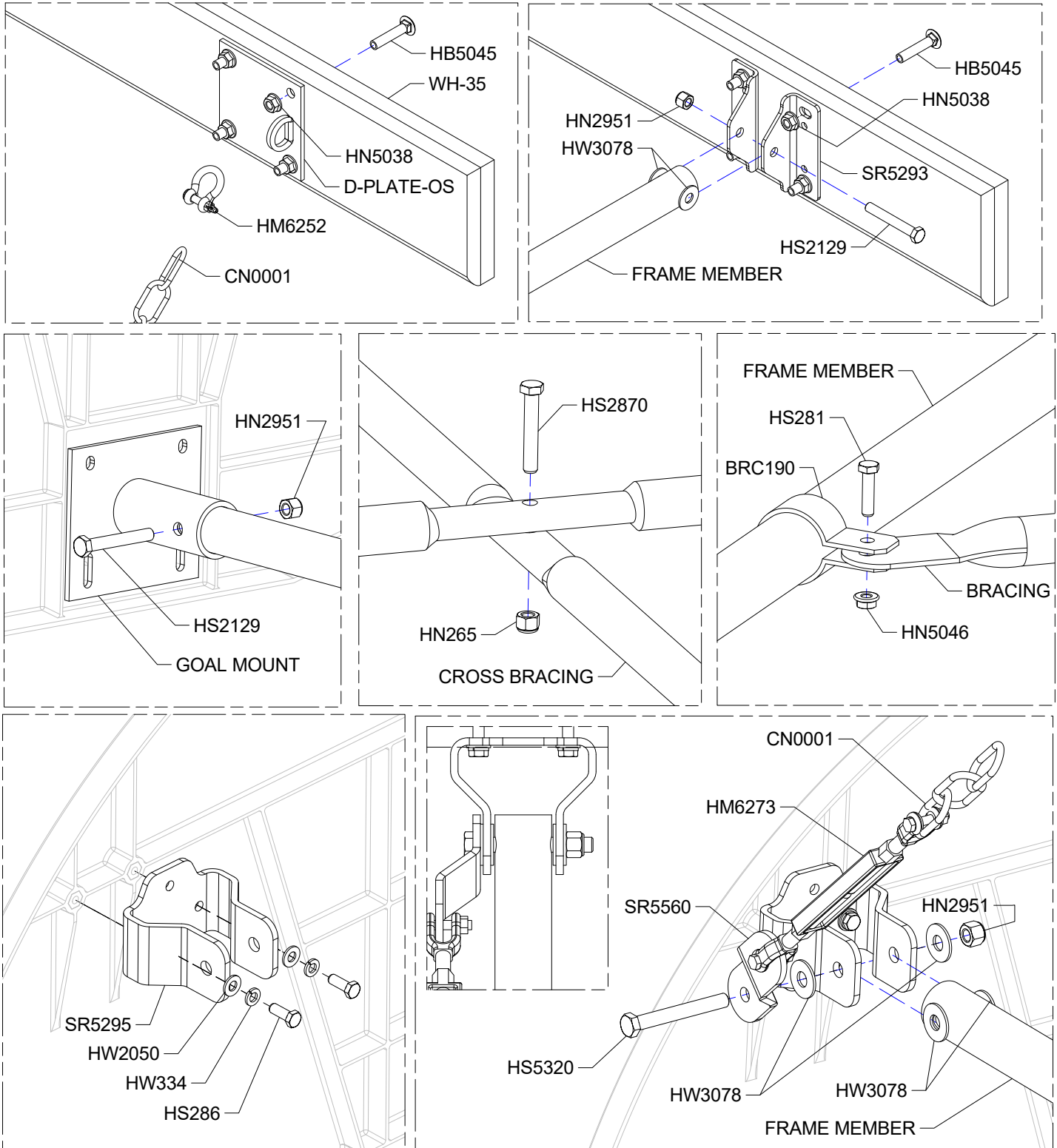



# JAYPRO WALL MOUNTED BACKSTOP

## INSTALLATION RECORD

**INSTALLER: PLEASE PROVIDE THE FOLLOWING INFORMATION AND FAX A COPY TO (860) 440-0628.**

INSTALLER NAME: \_\_\_\_\_  
 PHONE #: \_\_\_\_\_  
 DATE: \_\_\_\_\_

G.C. NAME: \_\_\_\_\_  
 PHONE #: \_\_\_\_\_

FACILITY NAME: \_\_\_\_\_  
(IN WHICH THIS BATTING CAGE WAS INSTALLED)

ADDRESS: \_\_\_\_\_  
 \_\_\_\_\_  
 \_\_\_\_\_

CONTACT NAME: \_\_\_\_\_  
(PERSON WHO RECEIVED KEYS FOR THE SYSTEM OR OTHER FACILITY REPRESENTATIVE)

PHONE #: \_\_\_\_\_

Call Jaypro Sports Equipment at 1-800-243-0533 during regular business hours for any technical support questions or issues. Refer to the applicable Wall Mount Model Number when talking to customer service personnel.

[www.jaypro.com](http://www.jaypro.com)

